



Development of a sensor system for mecatronic orthetic device

Huian Gheorghe – INCDMF
Cardei Vladimir – ICTCM

1. A modern concept – development of a robotized orthetic structure for persons with neuro locomotor deficiencies

Robotized orthetic structures are for persons with locomotor deficiencies and help their coordinate movement for the person displacement. The inferior limbs action is realized with actuators positioned outside of the orthese mechanic structure, in different accessible areas, according to the orthese constructive conception and the actuators type used.

Important scientific and technologic progress in the robotic, electronic and informatics fields provided some complex, performing and miniaturized devices which may replace the locomotor deficiencies of the assisted person.

In our country researches in the field are at the beginning, it was accomplished within the Research Program CEEEX-VIASAN a mecatronic orthetic device – project ROBOSIS.

The project coordinator was ICTCM and had as partners: P1 - Prof. Ctin Popovici Foundation; P2 - S.C. INCDTP – CERTEX S.A.; P3 – S.C. ICPE SA Bucuresti; P4 – INCDMF – CEFIN Bucuresti; P5 – UPB-OPTIMUM; P6 – SCUBA; P7 – S.C. COMPOZITE S.A. Brasov.

In the project INCDMF had as an objective the development of the sensors system for the mecatronic orthetic device.

2. The structure and functions of the mecatronic orthetic device

The structure of the mecatronic orthetic device includes the following main functional sub ensembles:

- a) Caring structure (exoskeleton segments, joints and fixing/attach elements of the orthetic device to the assisted person body);
- b) Actuators (electromagnetic subensembles necessary to act the joints);
- c) Sensors (sensors for measuring the joints angular position, sensors for pressure at the contact of the instep with the floor, sensors for teguments temperature control in the actuators area , sensors for controlling the teguments humidity for each segment of the locomotor device , orthostatic control function, etc.)
- d) Electronic ensemble for control (data acquisition modul, electronic bloc for data processing with microcontroller, electronic blocs for actuators control)
- e) Accumulators battery for electric energy supply of the othetic device;
- f) Interface structure between exoskeleton and the body of the assisted person at the tegument level;
- g) Esthetic cover of the mecatronic orthetic suit.

The orthetic mecatronic device must satisfy a wide range of requirements from the technical and medical point of view which should please the assisted person:

- to be a modular design which allows an easy intervention for eventual repairs and for the possibility of adapting easily the basic structure for different anthropometric measurements;
- to be an adequate design for an easy attachment / detachment to the body of the assisted person.

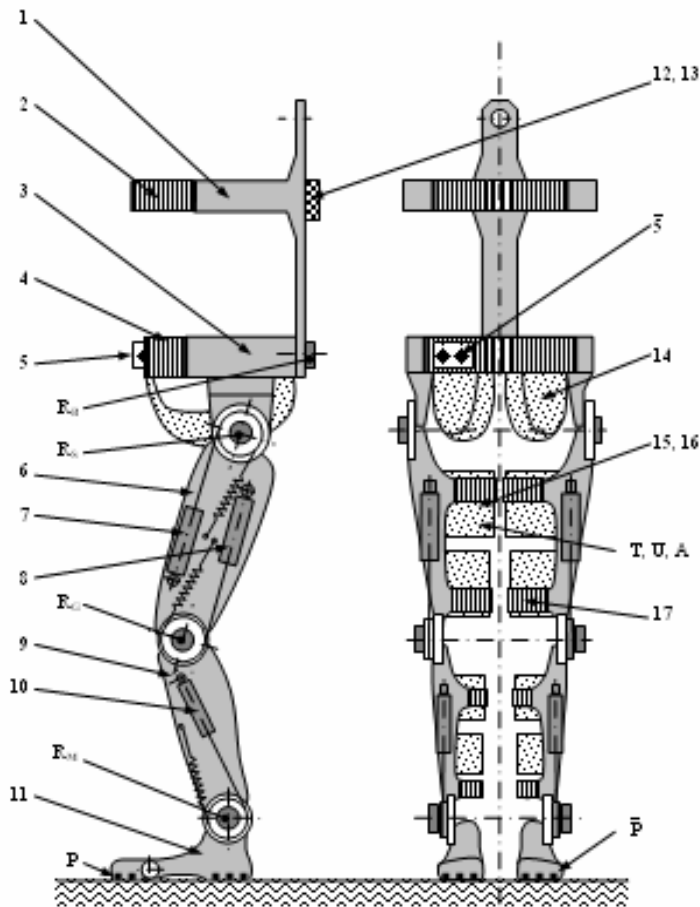

Fig.1. The principle scheme of the mecatronic orthetic device

Legend:

1 - back segment; 2 - breast belt; 3- basin segment; 4 - basin belt; 5 - box for program control;
6 - tight segment; 7- hip segment; 8- knee actuator; 9 - ankle segment; 10 - limb actuator;
11 - limb segment; 12- box for connections; 13- pneumatic connection screw; 14 - seat support; 15 - stoking with underwear; 16 - gonflable textile structure; 17- fixing belts type VELCRO;
R - angular transducer (B - basin: S - hip; G - knee; M - maleola);
P - pressure sensor; U - humidity sensor; A - sensor for compressed air pressure.

3. Sensors system for mechatronic orthetic device in informational interaction with the assisted person

For realizing an optimal functional regime of the mecatronic orthetic device with as much as possible displacements close to the natural walk and for comfort and safety reasons of the assisted person during walking the device is necessary to include a sensors system which permanently sends data/information to the central control ensemble for the controls made by the acting - actuators system and the pneumoelectric installation generating the peristaltic waves in the leg and tight for avoiding the vein lymphatic stanza according to the working program choosed by the assisted person.

The main groups of sensors necessary to equip the orthetic device are:

- a. sensors for defining the joints angular position;
- b. pressure sensors placed on the orthetic instep structure for defining the limb forces and position during walking and for accomplishing the orthostatic control function;
- c. sensors for teguments temperature control in the actuators area;
- d. sensors for controlling the teguments humidity for each segment of the locomotor device;
- e. sensors for controlling the compressed air pressure for supplying the gofers in order to generate peristaltic waves in the leg and tight arias.

3.1 Sensors for the relative angular position of the mecatronic orthetic device segments towards a reference position

For the relative angular position of the mecatronic orthetic device were used precision potentiometers fixed in the joints allowing to obtain an analogical output signal proportionally with the rotation angle.

The potentiometer is fixed on the joint axel whose angular position is controlled using an extensible coupling system which during functioning do not force the potentiometer axel and do not introduce errors of the movement transmission from the joint axel to the potentiometer axel.

3.2 Sensors for controlling the forces on the mecatronic orthetic device inlets in orthostatic and dynamic regime

For controlling the forces from the inlet mecatronic orthetic device is used an 8 force sensors, 4 sensors on each inlet as in the following figure.

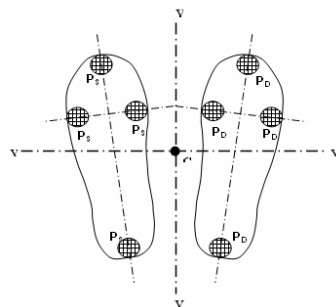

Fig.2. Disposition scheme of the sensors for inlet pressure

Force sensors system placed on the mecatronic orthetic device instep allows both the patient movement control in orthostatic and dynamic regime according to the functioning specific program and the protection of the assisted person for the accidental disequilibrium.

For the mecatronic orthetic device was choosed a force sensor from the FF100 series from the MEGATRON Elektronik AG – Germany realized as a cover that may be easily placed in a very small space.

The sensor is the resistive type ($\Delta R = 10 \text{ M}\Omega$) and during functioning is using a conditioning circuit generating an outlet signal in tension $0 \dots 5 \text{ V cc}$) proportionally to the measured force.

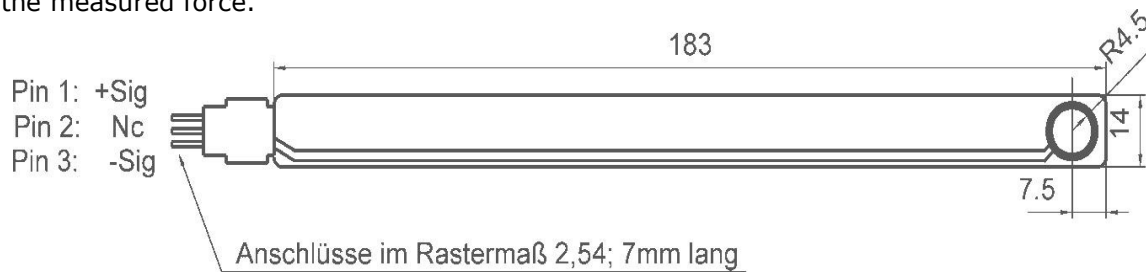

Fig. 3 Force sensor FF 100 – MEGATRON

Technical characteristics – force sensor type FF 100-440:

- resistive type sensor, measurement variety: $0 \dots 440 \text{ N}$;
- thickness: $0,1 \text{ mm}$;
- contact surface: $\varnothing 9 \text{ mm}$;
- resistance value for zero signal: $10 \text{ M}\Omega$
- resistance value for nominal signal: $20 \text{ K}\Omega$
- functioning temperature range: $-10 \dots +85 \text{ }^\circ\text{C}$;
- supply source: 5 Vdc .

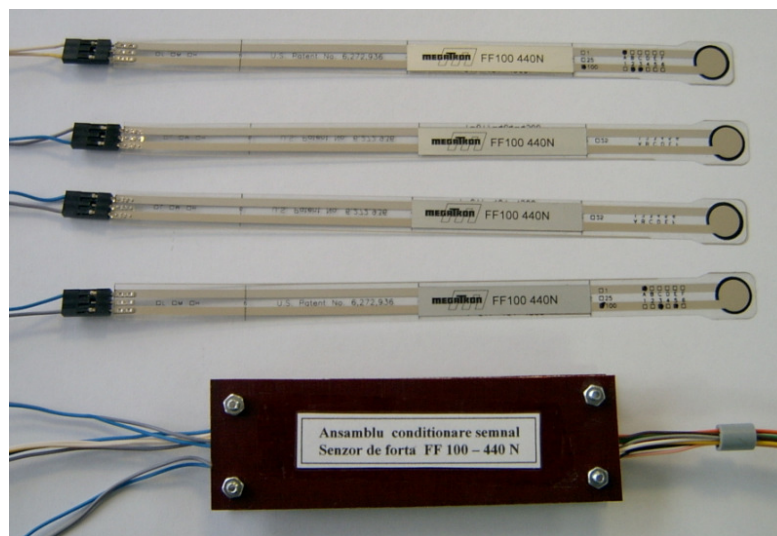

Fig.4 Conditioning signal ensemble for force sensors FF 100-440 N

3.3 Sensors for teguments temperature control

For teguments temperature control was used the LM35 sensor (National Semiconductor) associated with a signal conditioning signal generating an output signal of 0...5 V c.c. signal compatible with the input in the acquisition plate of the mecatronic orthetic device. Technical characteristics – temperature sensor LM35 (National Semiconductor):

- calibrated directly in Celsius degrees
- linear scale factor: +10,0 mV/°C;
- precision: 0,5°C at +25°C;
- measurement range: -55...+150°C;
- supply tension : +4,0...30 Vdc;
- supply current : < 60 μA.

For each leg was provided a signal conditioning plate with input for 2 temperature sensors.

The signal conditioning plates supply is made at a tension of 12 V c.c. The measurement signals for temperature and humidity are output tensions in the interval 0...5 V c.c.

3.4 Sensors for teguments humidity control

For measuring the relative humidity were choused Honeywell HIH4000-001 type sensors with the following technical characteristics:

- measurement range: 0...100% RH, environment without condense;
- accuracy : ± 3,5% RH;
- outlet tension: 0,9...4,0 Vdc for Vcc= 5 Vdc;
- functioning temperature range: -40...+85°C;
- tension supply: 4,0...5,8 Vdc;
- current supply: 500 μA maxim

The plate for signal conditioning circuit for temperature and humidity sensors has the following dimensions 108 x 29 mm, being realized with SMD components in order to realize a min. high dimension, so that the circuit plate may be inserted without difficulty in the mecatronic orthetic device component.

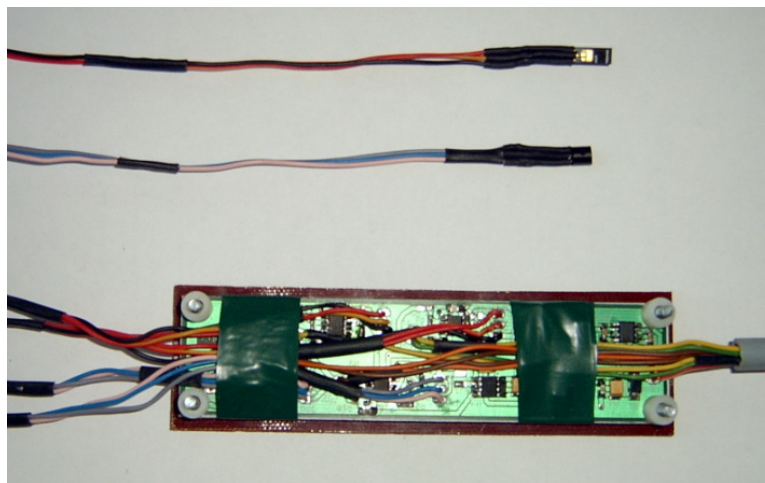

Fig.5 – Ensemble for signal conditioning for temperature and humidity sensors

3.5 Sensors for supply compressed air pressure control of the gofers for generating peristaltic waves

The pneumatic installation supplying with compressed air the gofers for generating peristaltic waves is equipped with an air pressure sensor allowing the correct functioning of the installation. The pressure sensor is placed on the gofers supply path. The compressed air pressure supplying the gofers is of 0,4...0,5 bar so that it was choused a pressure relay with the working domain of 0...1 bar, model SDE5-D2-FP-Q6E-P-K, from FESTO Company.

The pressure sensor for air pressure control on the gofers supply path is an intelligent/with electronic programming pressure relay generating a tension electric signal when touching a reestablished pressure values.



Fig.6. Pressure relay model SDE5-D2-FP-Q6E-P-K (FESTO)

Technical characteristics:

- measurement methods: piezoresistive pressure sensor
- pressure domain: 0...2 bar
- supply tension: 15 – 30 V c.c.
- output max curent : 100 mA
- output switch type : PNP
- display of the functioning status: LED
- working temperature: 0...50°C

4. Connection interface with the control system of the mecatronic orthetic device

Output signal in tension 0...5 V from the sensors system was introduced in a data acquisition plate Code 6035E (National Instruments) installed in the PC.

It was elaborated a data reading soft in Labview for temperature and pressure sensors (LM 35 + HIH 4000-01) and a data reading soft in Labview for the instep pressure sensors.

5. Conclusions

The obtained results allow the researches development for realizing a robotized, orthetic consume, objective included in the ongoing cooperation development within FP7 European Research Program.